

# Premium Drive PDD - PDX3

## Suit Machine Types: up to 2 tonne

Micro & Mini excavators, mini loaders, small skid steer loaders, to 2 tonne.

Built Digga tough for tough little machines. Digga Auger Drives are suitable for drilling holes for fencing, tree planting, house foundations & more.

### Features:

- High Quality Australian made Digga Gearbox
- Fitted with Digga/Eaton Bell motor
- Full factory backed 3 year warranty

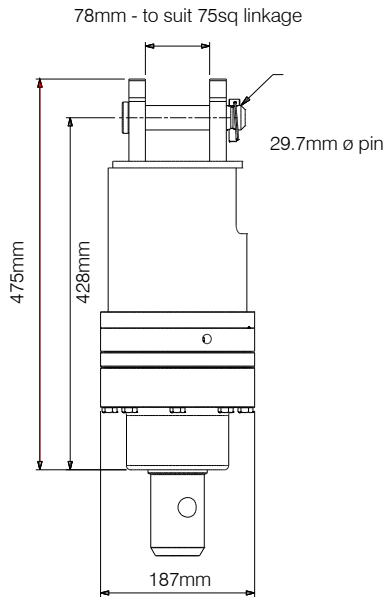

Specifications PDD, PDX, PDX2, PDX3	
Overall Length	620mm
Diameter	187mm
Weight (no frame/hitch)	59kg

Model	PDD	PDX	PDX2	PDX3
Min Rec Flow	15 lpm	20 lpm	30 lpm	45 lpm
Max Rec Flow	45 lpm	50 lpm	55 lpm	75 lpm
Max Torque (Nm) @ 240 bar	1200	1,800	2350	2850
STD Output Shaft #2	65mm Round	65mm Round	65mm Round	65mm Round
Recommended Auger Diameter				
Recommended Auger	A4	A4	A4	A4
Max Auger Dia Clay/Shale*	300mm	300mm	400mm	400mm
Max Auger Dia Earth*	400mm	400mm	500mm	500mm

PDD				PDX				PDX2				PDX3			
Output Speed		Output Torque		Output Speed		Output Torque		Output Speed		Output Torque		Output Speed		Output Torque	
Lpm	RPM	Bar	Nm	Lpm	RPM	Bar	Nm	Lpm	RPM	Bar	Nm	Lpm	RPM	Bar	Nm
15	49	125	600	20	44	125	900	30	50	125	1200	45	61	125	1500
20	66	145	700	25	55	145	1050	35	58	145	1400	50	68	145	1700
25	82	165	800	30	66	165	1200	40	66	165	1600	55	74	165	1950
30	98	185	900	35	77	185	1350	45	75	185	1800	60	81	185	2200
35	115	205	1050	40	88	205	1500	50	83	205	2000	65	88	205	2450
		220	1100	45	99	220	1650	55	91	220	2150	70	95	220	2600
		240	1200	50	110	240	1800			240	2350	75	101	240	2850

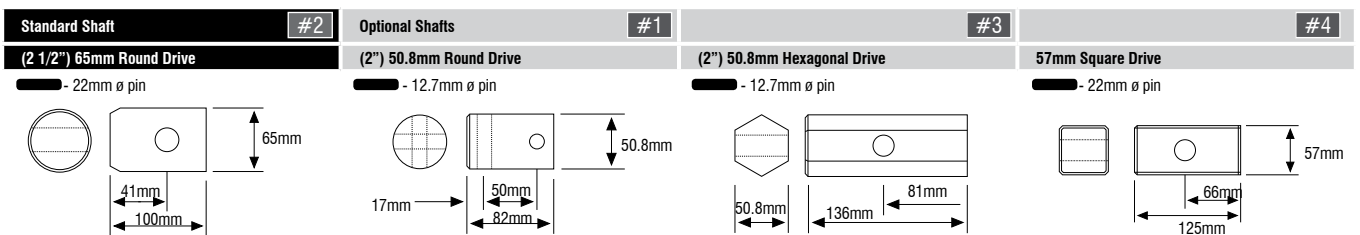

**DIGGA Head Office**  
**Brisbane QLD**  
 4 Octal Street,  
 Yatala QLD 4207  
 Ph: (07) 3807 3330  
 Fax: (07) 3807 1499

**DIGGA NSW**  
 1 Gallipoli St, Smeaton  
 Grange, NSW, 2567  
 Ph: (02) 4647 1400  
 Fax: (02) 4647 1433

**DIGGA VIC**  
 21-25 Villas Road  
 Dandenong VIC, 3175  
 Ph: (03) 9706 6171  
 Fax: (03) 9706 6164

**DIGGA WEST**  
 13 Yampai Way,  
 Willetton, WA, 6155  
 Ph: (08) 9457 1544  
 Fax: (08) 9457 0748

Email: info@digga.com Web: www.digga.com



## Premium Drive PD3 - PD4 Suit Machine Types: 3 to 4 tonne

mini machines, mini loaders, Mini excavators, skid steer loaders, tractors, tele-handlers, truck cranes, front end loaders, wheeled loaders, back hoes up to 4 tonne.

**Built Digga tough for tough little machines. Digga Auger Drives are suitable for drilling holes for fencing, tree planting, house foundations & more.**

### Features:

- High Quality Australian made Digga Gearbox
- Fitted with Digga/Eaton Bell motor
- Full factory backed 3 year warranty

78mm - to suit 75sq linkage

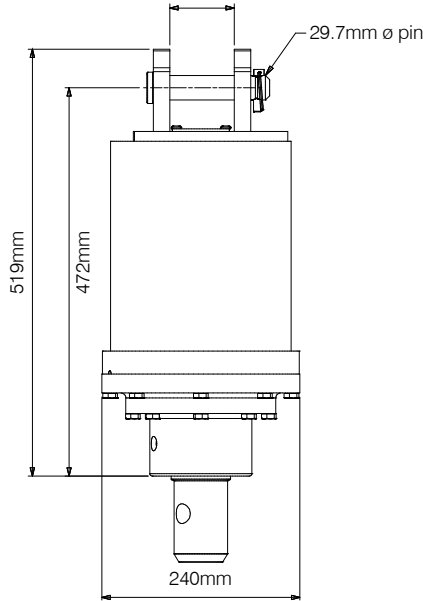

NEWGENERATION

Powered by  
**EATON**

### Specifications

Overall Length	624mm
Diameter	240mm
Weight (no frame/hitch)	60kg

Model	PD3	PD4-2	PD4-5	PD5
Min Rec Flow	45 lpm	50 lpm	50 lpm	60 lpm
Max Rec Flow	75 lpm	85 lpm	85 lpm	90 lpm
Max Torque (Nm) @ 240 bar	3600	4450	4450	5150
STD Output Shaft #2	65mm Round	65mm Round	75mm Square (#5)	75mm Square (#5)

Recommended Auger Diameter	PD3	PD4-2	PD4-5	PD5
Recommended Auger	A4	A4	A5/A6	A5/A6/A7
Max Auger Dia Clay/Shale*	400mm	400mm	400mm	600mm
Max Auger Dia Earth*	500mm	500mm	500mm	900mm

PD3				PD4-2				PD4-5				PD5			
Output Speed		Output Torque		Output Speed		Output Torque		Output Speed		Output Torque		Output Speed		Output Torque	
Lpm	RPM	Bar	Nm	Lpm	RPM	Bar	Nm	Lpm	RPM	Bar	Nm	Lpm	RPM	Bar	Nm
45	48	125	1850	50	43	125	2300	50	43	125	2300	60	45	165	3550
50	54	145	2150	55	47	145	2700	55	47	145	2700	65	48	175	3750
55	59	165	2450	60	52	165	3050	60	52	165	3050	70	52	185	3950
60	64	185	2750	65	56	185	3450	65	56	185	3450	75	56	195	4200
65	70	205	3050	70	60	205	3800	70	60	205	3800	80	60	205	4400
70	75	220	3300	75	64	220	4100	75	64	220	4100	85	63	220	4750
75	80	240	3600	80	69	240	4450	80	69	240	4450	90	67	240	5150
				85	73			85	73						

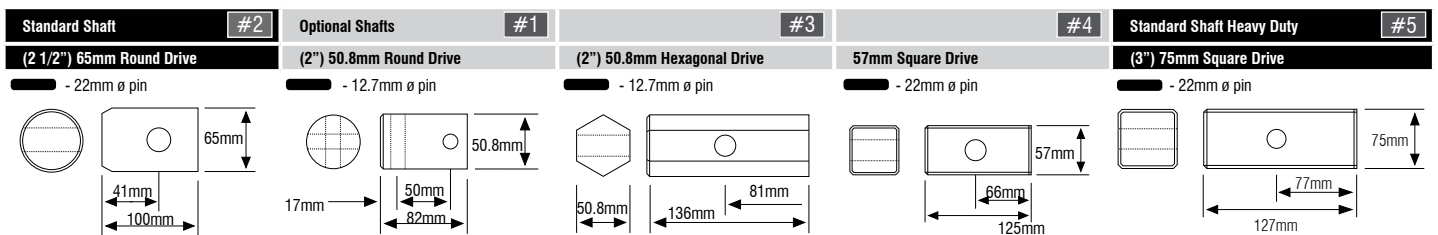

### DIGGA Head Office

#### Brisbane QLD

4 Octal Street,  
Yatala QLD 4207  
Ph: (07) 3807 3330  
Fax: (07) 3807 1499

### DIGGA NSW

1 Gallipoli St, Smeaton  
Grange, NSW, 2567  
Ph: (02) 4647 1400  
Fax: (02) 4647 1433

### DIGGA VIC

21-25 Villas Road  
Dandenong VIC, 3175  
Ph: (03) 9706 6171  
Fax: (03) 9706 6164

### DIGGA WEST

13 Yampi Way,  
Willeton, WA, 6155  
Ph: (08) 9457 1544  
Fax: (08) 9457 0748

Email: info@digga.com Web: www.digga.com



## Premium Drive PD6 - PD7

### Suit Machine Types: 4 to 11 tonne

skid steer loaders, tractors, tele-handlers, truck cranes, front end loaders, wheeled loaders, back hoes and excavators up to 11 tonne.

**Built Digga tough for tough little machines. Digga Auger Drives are suitable for drilling holes for fencing, tree planting, house foundations & more.**

#### Features:

- High Quality Australian made Digga Gearbox
- Fitted with Digga/Eaton Bell motor
- Full factory backed 3 year warranty

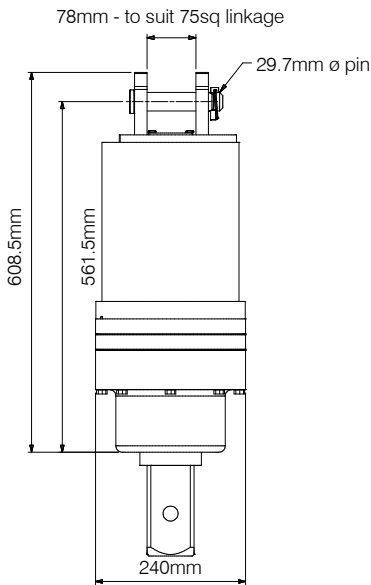

NEWGENERATION

Powered by  
**EATON**

#### Specifications

Overall Length	775mm
Diameter	240mm
Weight (no frame/hitch)	110kg

Model	PD6	PD6
Min Rec Flow	70 lpm	70 lpm
Max Rec Flow	115 lpm	115 lpm
Max Torque (Nm) @ 240 bar	5600	5600
STD Output Shaft #5	75mm Square	75mm Square
Recommended Auger Diameter		
Recommended Auger	A5/A6/A7	A5/A6/A7
Max Auger Dia Clay/Shale*	600mm	600mm
Max Auger Dia Earth*	900mm	900mm

PD6				PD7			
Output Speed		Output Torque		Output Speed		Output Torque	
Lpm	RPM	Bar	Nm	Lpm	RPM	Bar	Nm
70	48	165	3850	80	51	165	4150
75	51	175	4100	85	54	175	4400
80	55	185	4300	90	57	185	4650
85	58	195	4550	95	60	195	4900
90	61	205	4800	100	63	205	5150
95	65	220	5150	105	66	220	5550
100	68	240	5600	110	70	240	6050
105	72			115	73		
110	75						
115	79						

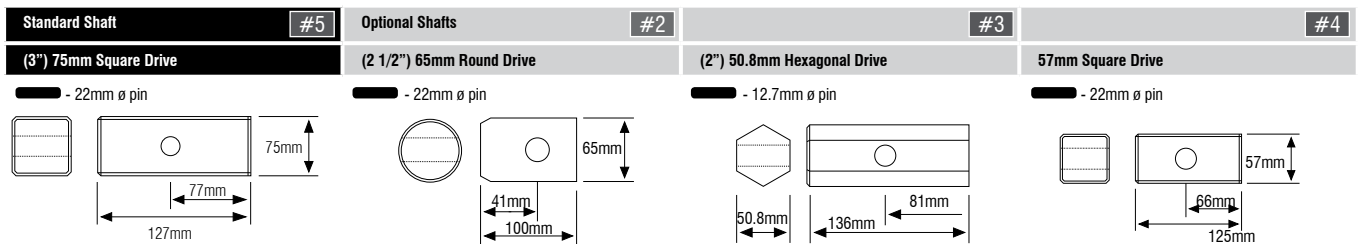

**DIGGA Head Office**  
**Brisbane QLD**  
4 Octal Street,  
Yatala QLD 4207  
Ph: (07) 3807 3330  
Fax: (07) 3807 1499

**DIGGA NSW**  
1 Gallipoli St, Smeaton  
Grange, NSW, 2567  
Ph: (02) 4647 1400  
Fax: (02) 4647 1433

**DIGGA VIC**  
21-25 Villas Road  
Dandenong VIC, 3175  
Ph: (03) 9706 6171  
Fax: (03) 9706 6164

**DIGGA WEST**  
13 Yampai Way,  
Willetton, WA, 6155  
Ph: (08) 9457 1544  
Fax: (08) 9457 0748

**Email:** info@digga.com **Web:** www.digga.com

## Premium Drive PD7 - PD8

### Suit Machine Types: 4 to 11 tonne

skid steer loaders, tractors, tele-handlers, truck cranes, front end loaders, wheeled loaders, back hoes and excavators up to 11 tonne.

**Built Digga tough for tough little machines. Digga Auger Drives are suitable for drilling holes for fencing, tree planting, house foundations & more.**

#### Features:

- High Quality Australian made Digga Gearbox
- Fitted with Digga/Eaton Bell motor
- Full factory backed 3 year warranty



NEWGENERATION

Powered by  
**EATON**

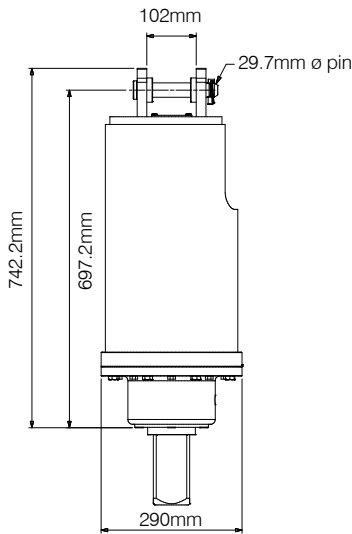

#### Specifications

Overall Length	775mm
Diameter	290mm
Weight (no frame/hitch)	110kg

Model	PD8	PD10
Min Rec Flow	80 lpm	90 lpm
Max Rec Flow	130 lpm	160 lpm
Max Torque (Nm) @ 240 bar	7050	8550
STD Output Shaft #5	75mm Square	75mm Square
Recommended Auger Diameter		
Recommended Auger	A6/A7	A6/A7
Max Auger Dia Clay/Shale*	900mm	900mm
Max Auger Dia Earth*	1000mm	1200mm

PD8				PD10			
Output Speed		Output Torque		Output Speed		Output Torque	
Lpm	RPM	Bar	Nm	Lpm	RPM	Bar	Nm
80	44	165	4850	90	41	165	5850
85	46	175	5100	95	43	175	6200
90	49	185	5400	100	45	185	6550
95	52	195	5700	105	47	195	6900
100	54	205	6000	110	50	205	7300
105	57	220	6450	115	52	220	7850
110	60	240	7050	120	54	240	8550
115	63			125	56		
120	65			130	59		
125	68			135	61		
130	71			140	63		
				145	65		
				150	68		
				155	70		
				160	72		

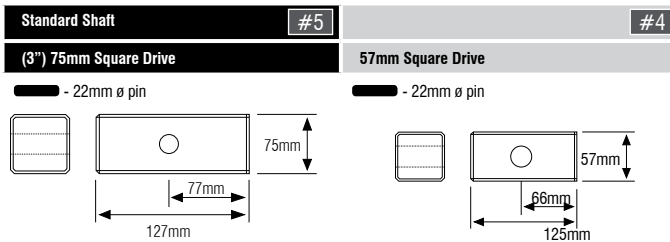

**DIGGA Head Office**  
**Brisbane QLD**  
4 Octal Street,  
Yatala QLD 4207  
Ph: (07) 3807 3330  
Fax: (07) 3807 1499

**DIGGA NSW**  
1 Gallipoli St, Smeaton  
Grange, NSW, 2567  
Ph: (02) 4647 1400  
Fax: (02) 4647 1433

**DIGGA VIC**  
21-25 Villas Road  
Dandenong VIC, 3175  
Ph: (03) 9706 6171  
Fax: (03) 9706 6164

**DIGGA WEST**  
13 Yampi Way,  
Willetton, WA, 6155  
Ph: (08) 9457 1544  
Fax: (08) 9457 0748

Email: info@digga.com Web: www.digga.com





## Premium Drive PD6HF - PD10HF

Suit Machine Types: 4 to 11 tonne

skid steer loaders, tractors, tele-handlers, truck cranes, front end loaders, wheeled loaders, backhoes and excavators up to 11 tonne.

**Built Digga tough for tough little machines. Digga Auger Drives are suitable for drilling holes for fencing, tree planting, house foundations & more.**

### Features:

- High Quality Australian made Digga Gearbox
- Fitted with 6K Digga/Eaton Bell motor
- Full factory backed 3 year warranty

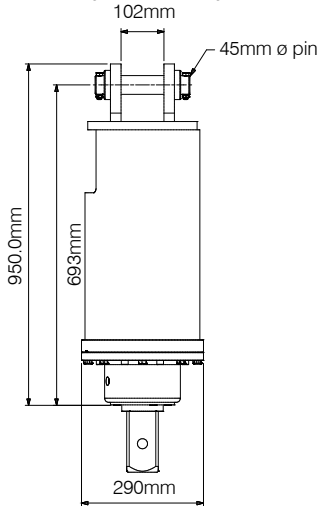

NEW GENERATION

Powered by  
**EATON**

### Specifications

Overall Length	950mm
Diameter	290mm
Weight (no frame/hitch)	140kg

Model	PD6HF	PD8HF	PD10HF
Min Rec Flow	70 lpm	100 lpm	100 lpm
Max Rec Flow	230 lpm	230 lpm	230 lpm
Max Torque (Nm) @ 240 bar	5600	7150	9750
STD Output Shaft #2	75mm Square	75mm Square	75mm Square
Recommended Auger Diameter			
Recommended Auger	A5/A6/A7	A6/A7	A6/A7
Max Auger Dia Clay/Shale*	600mm	900mm	900mm
Max Auger Dia Earth*	900mm	1000mm	1200mm

PD6HF				PD8HF				PD10HF			
Output Speed		Output Torque		Output Speed		Output Torque		Output Speed		Output Torque	
Lpm	RPM	Bar	Nm	Lpm	RPM	Bar	Nm	Lpm	RPM	Bar	Nm
70	47	100	2350	100	54	100	2950	95	37	100	4050
80	54	110	2600	110	59	110	3250	100	39	110	4450
90	61	120	2800	120	64	120	3550	110	43	120	4850
100	68	130	3050	130	70	130	3850	120	47	130	5250
110	75	140	3300	140	75	140	4150	130	51	140	5650
120	81	150	3500	150	80	150	4450	140	55	150	6050
130	88	160	3750	160	86	160	4750	150	59	160	6450
140	95	170	4000	170	91	170	5050	160	63	170	6850
150	102	180	4250	180	96	180	5350	170	67	180	7250
160	109	190	4450	190	102	190	5650	180	71	190	7650
170	115	200	4700	200	107	200	5950	190	75	200	8050
180	122	210	4950	210	112	210	6250	200	79	210	8500
190	129	220	5150	220	118	220	6550	210	83	220	8900
200	136	230	5400	230	123	230	6850	220	87	230	9300
210	142	240	5600			240	7150	230	91	240	9750
220	149										
230	156										

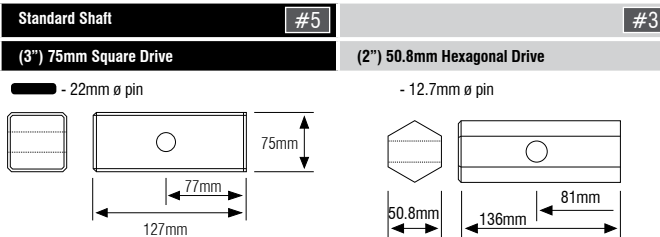

**DIGGA Head Office**  
**Brisbane QLD**  
4 Octal Street,  
Yatala QLD 4207  
Ph: (07) 3807 3330  
Fax: (07) 3807 1499

**DIGGA NSW**  
1 Gallipoli St, Smeaton  
Grange, NSW, 2567  
Ph: (02) 4647 1400  
Fax: (02) 4647 1433

**DIGGA VIC**  
21-25 Villas Road  
Dandenong VIC, 3175  
Ph: (03) 9706 6171  
Fax: (03) 9706 6164

**DIGGA WEST**  
13 Yampai Way,  
Willetton, WA, 6155  
Ph: (08) 9457 1544  
Fax: (08) 9457 0748

Email: info@digga.com Web: www.digga.com



# Premium Drive PD12

## Suit Machine Types: 12 to 15 tonne

Tele-handlers, truck cranes, front and loaders, excavators, wheeled loaders, back hoes up to 15 tonne.

**Built Digga tough for tough little machines. Digga Auger Drives are suitable for screw anchoring, core barrelling, drill rigs, deep drilling and foundation drilling & more...**

### Features:

- High Quality Australian made Digga Gearbox
- Fitted with 6K Digga/Eaton Bell motor
- Full factory backed 3 year warranty

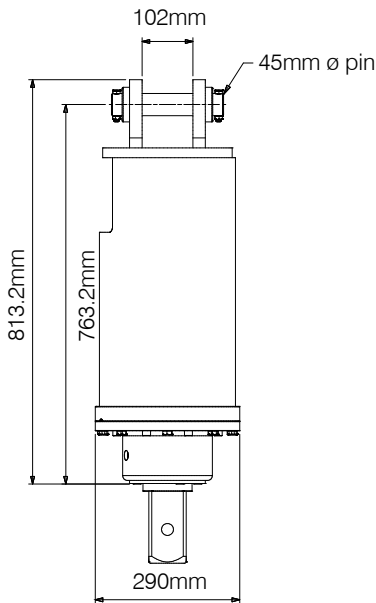

NEWGENERATION

Powered by  
**EATON**

### Specifications

Overall Length	969 mm
Diameter	290mm
Weight (no frame/hitch)	110kg

Model	PD12
Min Rec Flow	100 lpm
Max Rec Flow	230 lpm
Max Torque (Nm) @ 240 bar	11300
STD Output Shaft #5	75mm Square
Recommended Auger Diameter	
Recommended Auger	A8/A9
Max Auger Dia Clay/Shale*	900mm
Max Auger Dia Earth*	1500mm

PD12			
Output Speed		Output Torque	
Lpm	RPM	Bar	Nm
100	34	165	7750
110	39	175	8200
120	41	185	8650
130	44	195	9150
140	47	205	9650
150	51	220	10,350
160	54	240	11,300
170	58		
180	61		
190	64		
200	68		
210	71		
220	75		
230	78		

Standard Shaft	#5	Optional Shafts	#6
(3") 75mm Square Drive		75mm Long Square Drive	

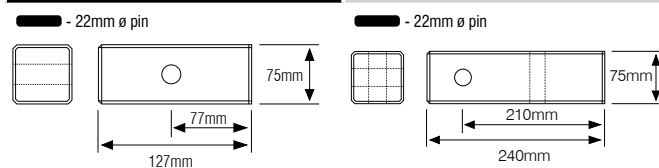

**DIGGA Head Office**  
**Brisbane QLD**  
4 Octal Street,  
Yatala QLD 4207  
Ph: (07) 3807 3330  
Fax: (07) 3807 1499

**DIGGA NSW**  
1 Gallipoli St, Smeaton  
Grange, NSW, 2567  
Ph: (02) 4647 1400  
Fax: (02) 4647 1433

**DIGGA VIC**  
21-25 Villas Road  
Dandenong VIC, 3175  
Ph: (03) 9706 6171  
Fax: (03) 9706 6164

**DIGGA WEST**  
13 Yampi Way,  
Willetton, WA, 6155  
Ph: (08) 9457 1544  
Fax: (08) 9457 0748

**Email:** info@digga.com **Web:** www.digga.com





## Premium Drive PD15 - PD22

Suit Machine Types: 15 to 24 tonne

Tele-handlers, truck cranes, front end loaders, wheeled loaders, back hoes, excavators up to 24 tonne. Built Digga tough for tough machines. Digga Auger Drives are suitable for screw anchoring, core barrelling, drill rigs, deep drilling and foundation drilling & more...

**Features:**

- High Quality Australian made Digga Gearbox
- Fitted with 6K Digga/Eaton Bell motor
- Full factory backed 3 year warranty

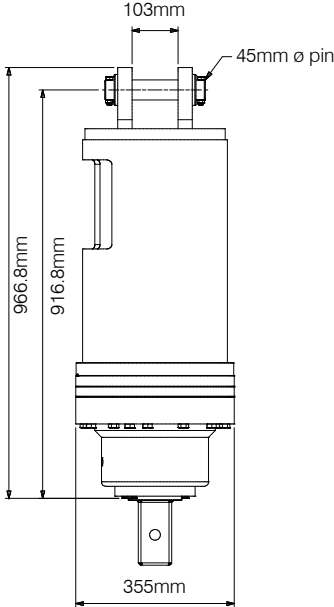

Specifications	
Overall Length	1056mm
Diameter	290mm
Weight (no frame/hitch)	270kg



Model	PD15	PD18	PD22
Min Rec Flow	125 lpm	130 lpm	140 lpm
Max Rec Flow	230 lpm	230 lpm	230 lpm
Max Torque (Nm) @ 240 bar	13,900	17,600	22,250
STD Output Shaft #5	75mm Square	75mm Square	75mm Square
Recommended Auger Diameter			
Recommended Auger	A8/A9	A8/A9	A8/A9
Max Auger Dia Clay/Shale*	900mm	1200mm	1200mm
Max Auger Dia Earth*	1500mm	1500mm	1500mm

PD15				PD18				PD22			
Output Speed		Output Torque		Output Speed		Output Torque		Output Speed		Output Torque	
Lpm	RPM	Bar	Nm	Lpm	RPM	Bar	Nm	Lpm	RPM	Bar	Nm
125	34	165	9550	130	28	165	12,100	140	24	165	15,300
130	36	175	10,150	140	30	175	12,900	150	26	175	16,210
140	39	185	10,700	150	33	185	13,600	160	28	185	17,150
150	41	195	11,300	160	35	195	14,300	170	29	195	18,050
160	44	205	11,900	170	37	205	15,050	180	31	205	19,000
170	47	220	12,750	180	39	220	16,150	190	33	220	20,400
180	50	240	13,900	190	41	240	17,600	200	34	240	22,250
190	52			200	43			210	36		
200	55			210	46			220	38		
210	58			220	48			230	40		
220	61			230	50						
230	63										

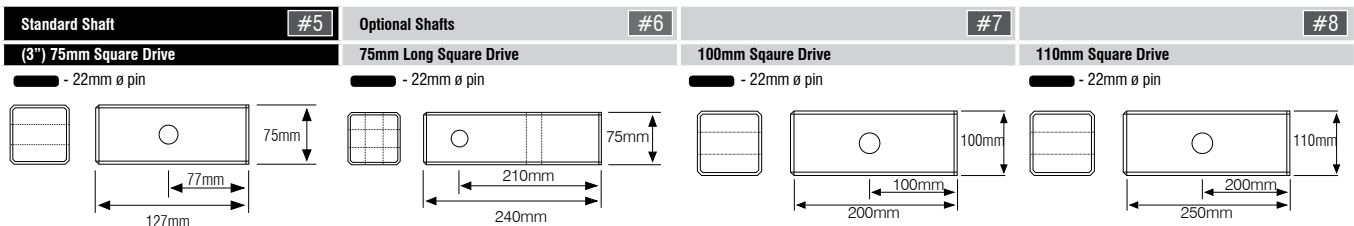

**DIGGA Head Office**  
**Brisbane QLD**  
 4 Octal Street,  
 Yatala QLD 4207  
 Ph: (07) 3807 3330  
 Fax: (07) 3807 1499

**DIGGA NSW**  
 1 Gallipoli St, Smeaton  
 Grange, NSW, 2567  
 Ph: (02) 4647 1400  
 Fax: (02) 4647 1433

**DIGGA VIC**  
 21-25 Villas Road  
 Dandenong VIC, 3175  
 Ph: (03) 9706 6171  
 Fax: (03) 9706 6164

**DIGGA WEST**  
 13 Yampi Way,  
 Willetton, WA, 6155  
 Ph: (08) 9457 1544  
 Fax: (08) 9457 0748

Email: info@digga.com Web: www.digga.com



## Premium Drive PD25 - PD50

Suit Machine Types: 24 to 50 tonne

Tele-handlers, truck cranes, front end loaders, wheeled loaders, back hoes, excavators up to 50 tonne.  
**Built Digga tough for tough machines. Digga Auger Drives are suitable for screw anchoring, core barrelling, drill rigs, deep drilling and foundation drilling**

**Features:**

- High Quality Australian made Digga Gearbox
- Fitted with 6K Digga/Eaton Bell motor
- Full factory backed 3 year warranty

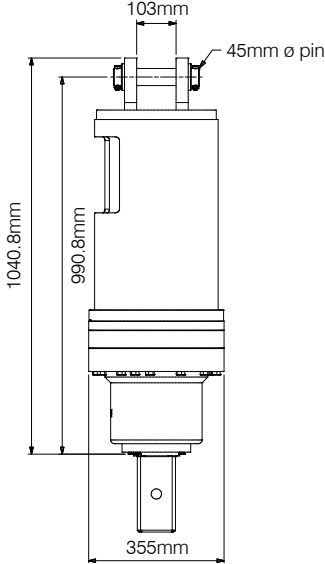

NEW GENERATION

Powered by  
**EATON**

**Specifications**

Overall Length	1316mm
Diameter	355mm
Weight (no frame/hitch)	310kg

Model	PD25	PD30	PD40	PD50
Min Rec Flow	140 lpm	150 lpm	150 lpm	150lpm
Max Rec Flow	230 lpm	230 lpm	230 lpm	230lpm
Max Torque (Nm) @ 240 bar	25,800	30,300	32,700	38,400
STD Output Shaft #5	100mm Square	100mm Square	100mm Square	100mm Square
Recommended Auger Diameter				
Recommended Auger	A10/A11	A10/A11	A10/A11	A10/A11
Max Auger Dia Clay/Shale*	1500mm	1500mm	1800mm	1800mm
Max Auger Dia Earth*	1800mm	1800mm	2000mm	2000mm

PD25				PD30				PD40				PD50			
Output Speed		Output Torque		Output Speed		Output Torque		Output Speed		Output Torque		Output Speed		Output Torque	
Lpm	RPM	Bar	Nm	Lpm	RPM	Bar	Nm	Lpm	RPM	Bar	Nm	Lpm	RPM	Bar	Nm
140	21	165	17,750	150	19	165	20,850	150	18	165	22,500	150	15	165	26,400
150	22	175	18,850	160	20	175	22,100	160	19	175	23,900	160	16	175	28,000
160	24	185	19,900	170	21	185	23,350	170	20	185	25,250	170	17	185	29,600
170	25	195	21,000	180	23	195	24,600	180	21	195	26,600	180	18	195	31,200
180	27	205	22,050	190	24	205	25,900	190	22	205	27,950	190	19	205	32,800
190	28	220	23,650	200	25	220	27,800	200	23	220	30,000	200	20	220	35,200
200	30	240	25,800	210	26	240	30,300	210	25	240	32,700	210	21	240	38,400
210	31			220	28			220	26			220	22		
220	33			230	29			230	27			230	23		
230	34														

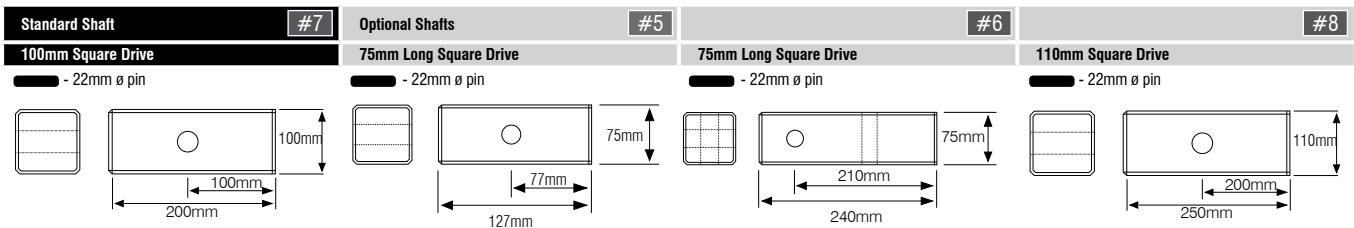

**DIGGA Head Office**  
**Brisbane QLD**  
 4 Octal Street,  
 Yatala QLD 4207  
 Ph: (07) 3807 3330  
 Fax: (07) 3807 1499

**DIGGA NSW**  
 1 Gallipoli St, Smeaton  
 Grange, NSW, 2567  
 Ph: (02) 4647 1400  
 Fax: (02) 4647 1433

**DIGGA VIC**  
 21-25 Villas Road  
 Dandenong VIC, 3175  
 Ph: (03) 9706 6171  
 Fax: (03) 9706 6164

**DIGGA WEST**  
 13 Yampi Way,  
 Willetton, WA, 6155  
 Ph: (08) 9457 1544  
 Fax: (08) 9457 0748

**Email:** info@digga.com **Web:** www.digga.com

